

* Axles holes should be drilled
 2.5° angle or axles should be bent
 at 2.5°. Note: Side of block is
 sanded at angle as well.

Pinewood Derby Template

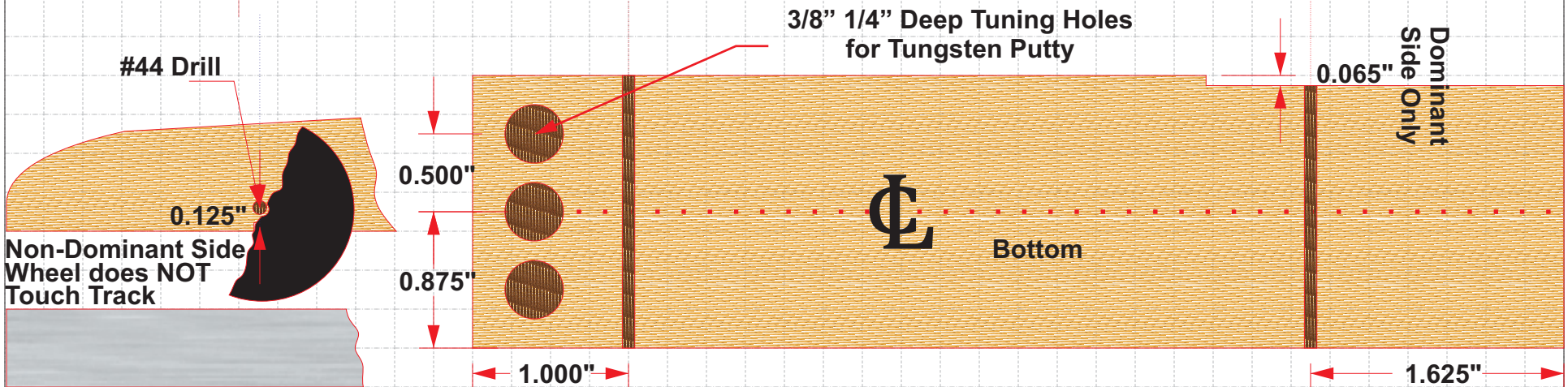
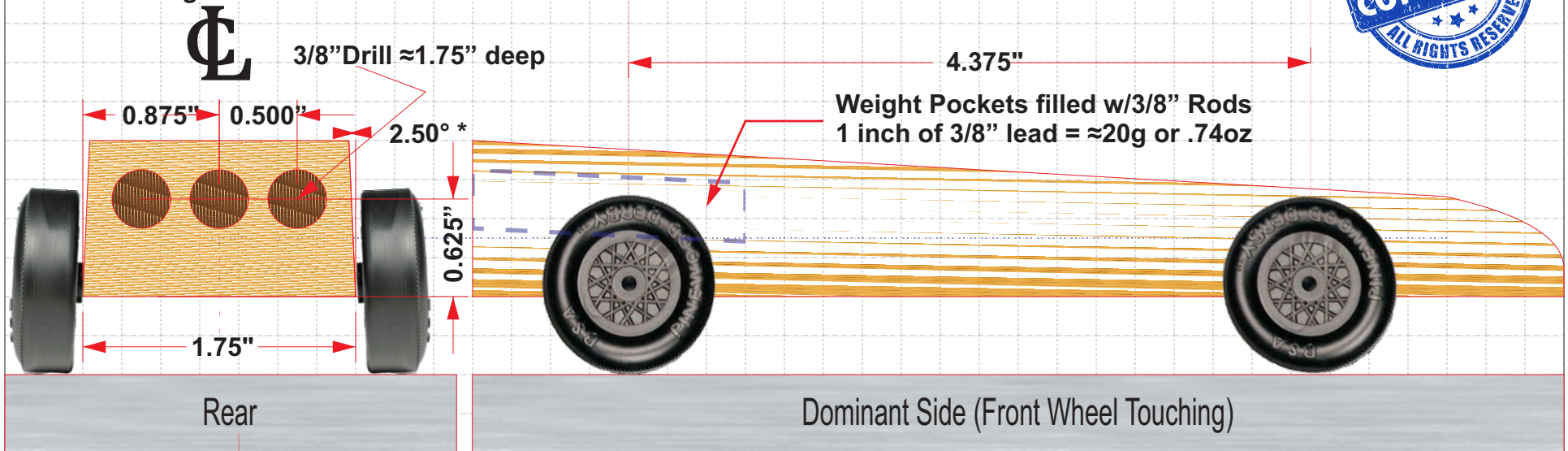

Description: 45 Minute Car
 Designer: Lee Dabkey
<https://octopi-racing.com/>
 Date: 12/11/2018

This is a simple, FAST car that can be built in under an hour with the proper tools. It requires a 3/8" and #44 drill bit with a drill press (preferable). A coping saw or band saw should be used to cut the profile. A power sander is preferable for beveling the sides and for the dominant wheel cut-in.

Scale: 1:1

